



PUNTO FILO RANGE

Wall axial fans

For intermittent or continuous ventilation of bathrooms, toilets, kitchens or utility rooms in domestic or commercial properties.



- **17 models:** from 90 to 150 diameters, standard, timer, long life versions.
- Integral backdraught shutter: already installed on the appliance, it prevents unwanted air from getting back in when the appliance is switched off.
- Very silent.
- Quick and easy installation.
- Eco-Friendly: it guarantees a low environmental impact.
- Only 17 mm thickness.
- **Punto Filo T-HCS:** 3 models.
Adjustable RH threshold at 60%, 70%, 80%, 90% by mean of a slide switch during installation.
- Protection rating: IPX4.
- Insulation class: II. □

Design: F. Trabucco & Associates

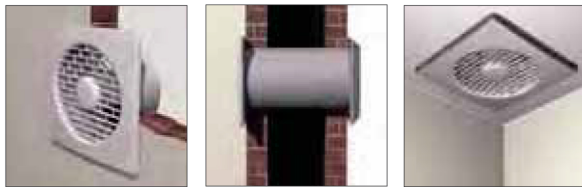

Wiring diagrams shown from page 458

TECHNICAL DATA

Models	V~50Hz	W	A	RPM	Max Airflow		Max Pressure		Lp dB(A) 3m	Max °C
					m³/h	l/s	mmH₂O	Pa		
MF 90/3.5"	230 - 240	14	0.08	2500	65	18	2.5	25	28.8	50
MF 100/4"		15	0.09	2400	85	24	3	29	31	
MF 120/5"		20	0.12	2150	175	49	5	49	34.4	
MF 150/6"		28	0.15	2100	335	93	6	59	40.1	

DIMENSIONS

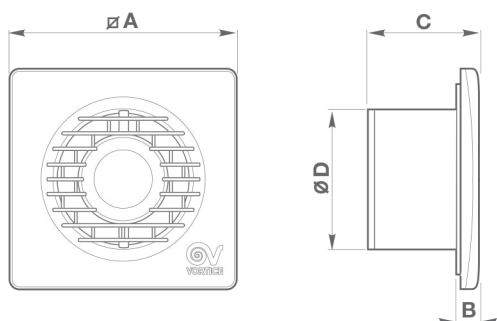



Models	∅A	B	C	∅D	Kg
MF 90/3.5"	159	17	77	92.5	0.50
MF 100/4"			98	0.51	
MF 120/5"	179		89	119	0.61
MF 150/6"	214		96	156	0.97

Dimensions (mm)



Punto Filo		STANDARD	LONG LIFE 30.000 h
Ø90	Basic	11122	-
	Timer	11126	-
Ø100	Basic	11123	11131
	Timer	11127	11135
	Timer PIR	-	11185
	Timer HCS	-	11139
Ø120	Basic	11124	11132
	Timer	11128	11136
	Timer PIR	-	11186
	Timer HCS	-	11149
Ø150	Basic	11125	11133
	Timer	11129	11137
	Timer PIR	-	11187
	Timer HCS	-	11176

PRODUCT ACCESSORIES

Models		Code	Product																			
			MF 90/3.5" Code 11122	MF 90/3.5" T Code 11126	MF 100/4" Code 11123	MF 100/4" LL Code 11131	MF 100/4" T Code 11127	MF 100/4" T LL Code 11135	MF 100/4" T P LL Code 11185	MF 100/4" T-HCS LL Code 11135	MF 120/5" Code 11124	MF 120/5" LL Code 11132	MF 120/5" T Code 11128	MF 120/5" T LL Code 11136	MF 120/5" T P LL Code 11149	MF 120/5" T-HCS LL Code 11136	MF 150/6" Code 11125	MF 150/6" LL Code 11133	MF 150/6" T Code 11129	MF 150/6" T LL Code 11137	MF 150/6" T P LL Code 11187	MF 150/6" T-HCS LL Code 11176
	C 1.5 Electronic speed controller 1.5 A	12966	•		•	•					•	•					•	•				
	SCB KIT Built-in controller adaptor for C 1.5	22481																				
	SF 90-100 Ceiling kit Ø 90-100	22162	•	•	•	•	•	•	•	•												
	SF 120 Ceiling kit Ø 120	22163									•	•	•	•	•	•						
	SF 150 Ceiling kit Ø 150	22164															•	•	•	•	•	•

Description and sizes on page 126; System components on page 330.

PERFORMANCE CURVES

MF 90/3.5"

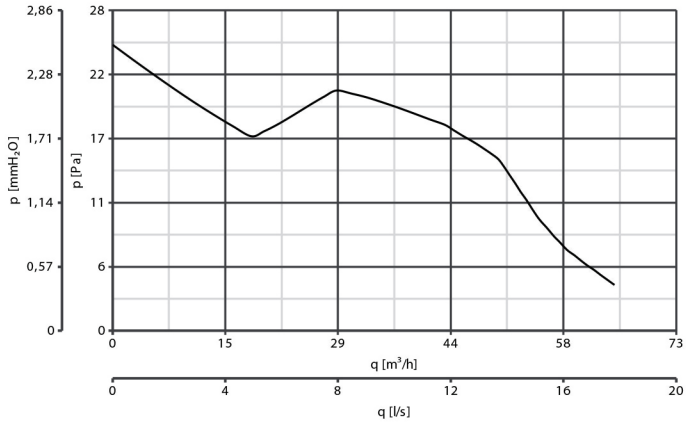

MF 100/4"

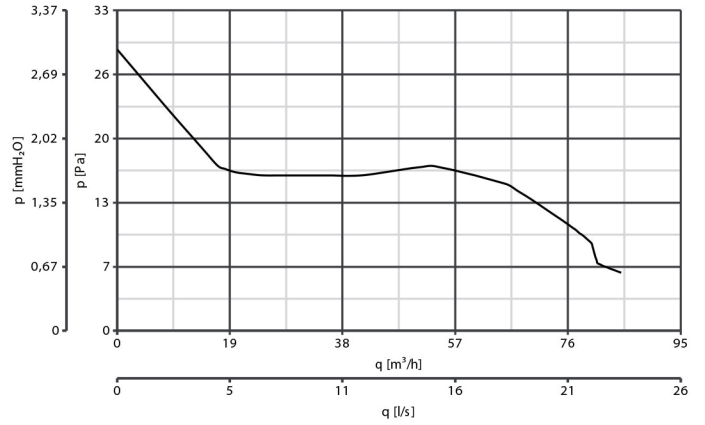

MF 120/5"

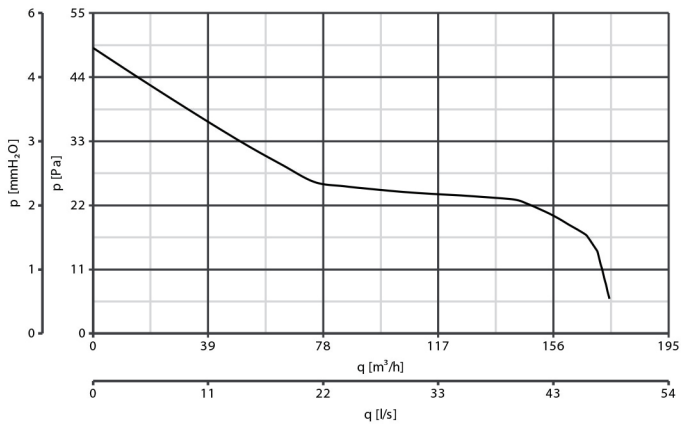

MF 150/6"

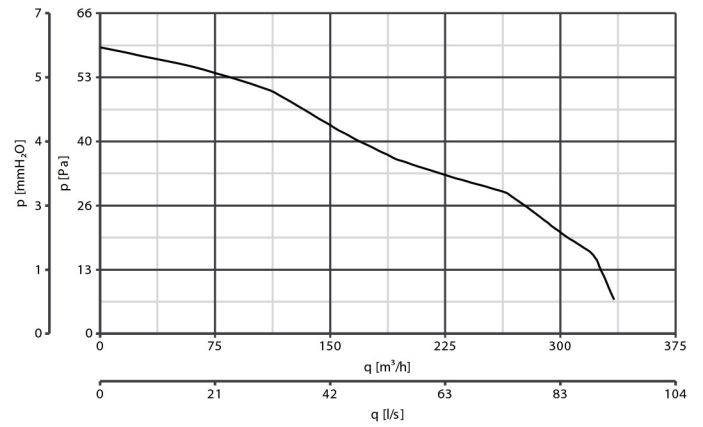

— static pressure